

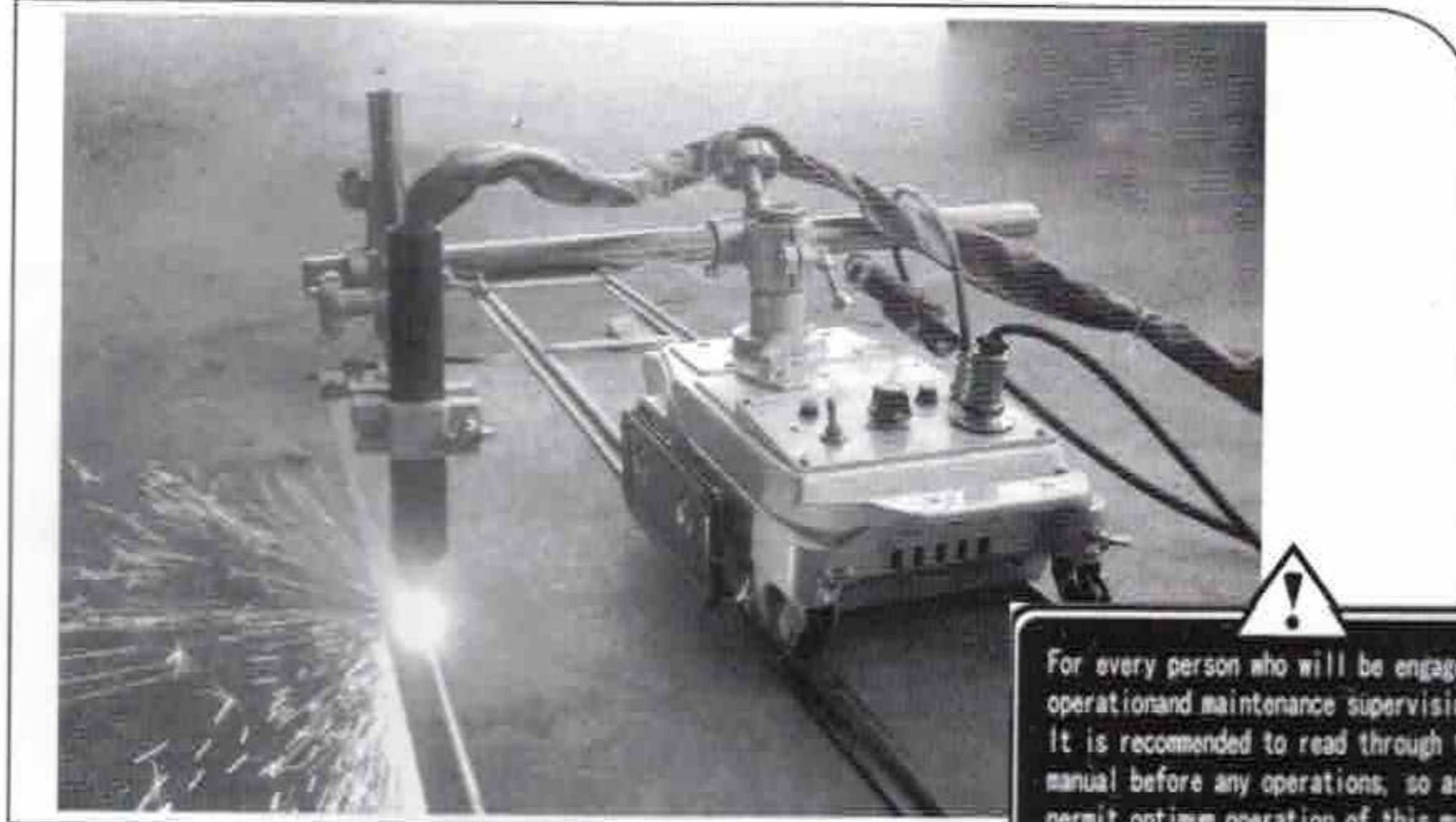



OPERATING INSTRUCTIONS



For every person who will be engaged in operation and maintenance supervision, it is recommended to read through this manual before any operations, so as to permit optimum operation of this machine. Hold this manual carefully so that you can use it next time.

CG1-30K Fast Gas Cutting Machine

INSTRUCTION

Thank you very much for purchasing this product. Read this instruction manual thoroughly to insure correct, safe and effective use of the machine. Read the manual first to understand how to operate and maintain the machine.

Make sure you read, understand and take all the necessary safety precautions.

SAFETY PRECAUTIONS

This product is designed to be safe, but it can cause serious accidents if not operated correctly. Those who operate and repair this machine must read this manual thoroughly before operating, inspecting and maintaining the machine. Keep the manual near the machine so that anyone who operates the machine can refer to it if necessary.

- Do not use the machine carelessly without following the instructions in manual.
- Use the machine only after you completely understood the contents of the manual.
- If an explanation in the manual is difficult to understand, contact our company of sales service office.
- Keep the manual nearby at all times and read it so many times as necessary for a complete understanding.
- If the manual become lost or damaged, place an order with our company or sales service office for a new one.
- When transferring the machine to a new owner, be sure to hand over this instruction manual as well..

QUALIFICATIONS FOR MACHINE OPERATOR

Operators and repair staff of this machine must completely understand the contents of the instruction manual and they must be qualified and educated to handle this equipment.

1. The license for gas welding ganger
2. The diploma of the training course on gas welding.
3. The qualification certificate approbated by the ministry of labor.

Symbol	Title	Meaning
	General	General caution, warning and danger
	Be careful not to get your fingers caught.	Possible injury to fingers if caught in the insertion part.
	Caution: Electric shock!	Possible electric shock under special conditions.
	Ground this equipment.	Operators must ground the equipment using the safety grounding terminal.
	Pull out the power plug from the outlet.	Operators must unplug the power plug from the outlet when a failure occurs or when there is a danger of lightning.
	Caution against bursting	Possible bursting under certain conditions.
	General	General warning.
	Caution: Hot !	Possible injury due to high temperature under certain conditions.
	Caution: Ignition!	Possible ignition under certain conditions.

CONTENTS

1. Safety instruction	1
1.1 General operation safety precautions	1
1.2 Gas cutting safety precautions.....	3
2. Location of safety labels.....	6
3. Outline of machine	6
3.1 Characters	6
3.2 Name and function of each section	7
3.3 Specifications.....	7
4. Preparation for operation	8
4.1 Contents of package.....	8
4.2 Machine assembly	8
4.3 Preparation for operation.....	9
5. Cutting operation.....	10
5.1 Safety measure before operation.....	10
5.2 Ignition and flame adjustment	10
5.3 Methods of cutting and piercing	11
5.4 Cutting operation and steps of blanking flame.....	11
5.5 Safety measures against backfire and flash back.....	14
6. Maintenance and inspection.....	15
6.1 Gear case maintenance	15
6.2 Tip maintenance.....	15
6.3 Carbon brush maintenance	15
7. Trouble shooting	16
8. Wiring diagram	17
9. Maintenance illustration	17

1 Safety instruction

Operation, inspection, and maintenance that are against the basic safety rules can cause many accidents. Carefully read, understand, and master the safety measures and precautions described in this instruction manual and on the machine before operating, inspecting, and maintaining the machine. The safety messages are classified as following.

■ WARNING

This word is used as a warning message or a warning label. It is positioned at places that could cause injury or serious accident.

■ CAUTION

This word is used as a caution message or a caution label. It is positioned at places that could cause slight injury or machine damage. This is also used as a caution for high dangerous actions.

■ NOTICE SIGNS

This is a sign to show machine operators and maintenance engineers items that relate directly to damage of machines and surrounding facilities and equipment.

1.1 General machine safety precautions

Read and understand the following important safety information:

1.1.1 Machine safety

1. The machine casing is mainly made of aluminum alloy to reduce weight. For this reason, be careful not to drop a heavy item on the machine, or not to drop the machine when carrying it, since the alloy is not designed to withstand such impact.
2. When fixing hoses to the torch and distributor, tighten the nut with the attached wrench. After fixing, be sure to check there is no gas leak with a detection liquid. If a gas leak is found, retighten the nut firmly.
3. When fixing a tip to the torch, tighten the nut with the two wrenches. In addition, avoid damaging the taper part of the tip since this may cause backfire.
4. Never disassemble the machine other than during maintenance and inspection. Otherwise, malfunction will occur.
5. Never remodel the machine. Remodeling is very dangerous.
6. Must cut the power off when the machine is not in use.
7. Never use the machine outdoors when the weather is wet. This will cause failure of the machine and could cause a fatal accident due to electric shock.

1.1.2 Safety clothing

1. Be sure to wear protector's gauntlets, goggles, helmet, and safety shoes during operation.
2. Avoid operating the machine with wet clothes or hands in order to prevent electric shock.

1.1.3 Safety precautions before operation and carrying

1. Read this instruction manual before operating the machine.
 2. Make sure the machine is assembled rightly on rail before operation and the guide wheel is in the groove.
 3. Make sure the speed regulating knob is on the " stop" position before turning on power.
 4. Prior to operating the machine, check the safety of the surroundings to avoid accidents.
 5. Never move the machine while the preheating flame burns.
 6. When you use the guide rail to do linear cut, you should clean the groove. Else, it will impact the cutting quality.
 7. Don't knock the rail.
 8. The rail is made of manganese steel. It has characters of elastic behavior and wear-resisting. So, you can't force to bend the rail too much in the process. It can't recover if the bend is beyond of flexural strength.
 9. You must tighten the locating screw of universal wheel when you cut along straight line.
 10. When the great circle cutting is over, you should be careful not to make the machine and steel products drop.
 11. You should release the locating screw of universal wheel to make the universal wheel revolve freely when cutting great circle and arc.
 12. Direction changeover switch
 - The direction changeover switch is used to change the direction of going forward / falling back of linear cut or clockwise revolution/anti-clockwise revolution of arc cut. Check the running direction or the direction of knob before cutting.
 - When changing the direction of running, you should make the driving button be on the " stop" position. And change the direction of running after the machine comes to a full stop.
- Instruction: Before the power is turned on, it is necessary to check if the driving button is on the " stop" position. It is very dangerous to operate the machine when the driving button is on the " on" position.
13. Don't touch the rotary section (propelling wheel) to avoid accidents.
 14. Don't make the machine be shocked in the process of cutting.
 15. Connect the gas hoses rightly.
 16. You must close preheat valve and fuel gas valve when checking the running of the machine before operation and cutting allocation.
 17. The bottom of the nozzle, torch and the butterfly-screws etc are very hot after cutting, so it is necessary to wear gloves if you want to touch them.

18. If the machine falls down, it may reduce the length of life and damage gas valve to lead to gas leakage.
19. You must not drag the cable of power supply.
20. Don't put the machine on soil or muddiness.
21. Don't leave the machine alone before it flames out.
22. You must use hose-hoop in case of dangers.
23. When the fuse burns out frequently, it is not allowed to use high-current fuse before finding out the cause.
24. When carrying the machine, you must hold the handlebar and can't hold other sections

1.1.4 Electrical system precautions



1. Check the input power voltage of the machine before operation. The input power voltage should be in the range of $\pm 10\%$ of the rated voltage. The machine should not be operated out of this range.
2. The metal plugs are screw-threaded. Therefore, you should tighten them so that they will not loose during operation.
3. Be sure to ground the power cable of the machine.
4. **Stop operation and cut off the power in the following cases, and ask a qualified electrician to repair the machine.**
 - 1) Broken or abraded cables.
 - 2) Leak of water or liquid, which damages the machine.
 - 3) The machine operates abnormally despite of operating the machine according to the instruction manual.
 - 4) Machine is broken down.
 - 5) The machine has a poor performance and needs to be repaired.
5. Periodically inspect the electrical system.

1.1.5 Maintenance and inspection precautions



1. Ask a qualified electrician to perform repair and inspection service.
2. Disconnect the power plug before inspecting and repairing the machine.
3. Maintain the machine periodically.

1.2 Gas cutting safety precautions

Strictly observe the safety rules and precautions to ensure the safety of gas cutting operations. Operators and supervisors MUST keep " safety" in mind.

1.2.1 Prevention of explosion



1. Never cut pressurized cylinders or hermetically sealed containers.
2. Ensure sufficient ventilation for gas cutting to prevent the air from being polluted.

1.2.2 Pressure regulator safety precautions



1. Before operating, check that all pressure regulators are operating correctly.
2. Ask a skilled repair engineer to perform maintenance and inspection service.
3. Do not use malfunctioning pressure regulators or pressure regulators from which gas is leaking.
4. Do not use pressure regulators smeared with oil or grease.

1.2.3 High pressure gas cylinder safety precautions



1. Never use broken cylinders or cylinders from which gas is leaking.
2. Install cylinder upright and take measures to prevent them from falling.
3. Use cylinders only for specified purposes.
4. Do not use pressure regulators smeared with oil or grease.
5. Install cylinders in a place free from heat, sparks, slag, and open flame.
6. Contact the distributor if the container valves will not be opened. Never use a hammer, wrench, or other tools to forcibly open container valves.

1.2.4 Safety precaution for hoses



1. The oxygen hose is used for transporting oxygen gas only.
2. Replace cracked hoses or other hoses damaged by sparks, heat, unshielded fire, etc.
3. Install hoses without twisting.
4. Take great care during operation and transportation to prevent hoses from breakage.
5. Do not drag the hoses when moving the machine.
6. Periodically check the hoses for damage, leakage, fatigue, loose joints, etc, to ensure safety.
7. Cut hoses to the minimum possible length. Short hoses reduce hose damage and pressure drop, as well as reduce the flow resistance.

1.2.5 Safety precautions for fire



Take safety precautions to avoid fire before cutting.

It could cause a fire due to ignoring hot metal, sparks, and slag.

1. Keep a fire extinguisher, fire extinguish sand, bucket full of water, etc. be ready on the site where gas cutting is performed.
2. Keep flammables away from the cutting area to avoid splashing sparks.
3. Before bringing the hot steel plates, as well as hot cut parts or scrap, to flammables, you must cool down them.
4. Never cut containers, which flammable materials are stuck to.

1.2.6 Safety precautions for skin burns



Observe the safety precautions to avoid burning skin. It could cause a fire or burning skin due to ignoring heat, spatter, and sparks during operation.

1. Do not perform cutting near flammables. (Move flammables well away from the sparks.)
2. Do not cut containers filled with flammables.
3. Do not keep lighters, matches, and other flammables near by.
4. Flames from the torch will burn the skin. Keep your body away from the torch and tip, and check the safety before operating the switches and valves.
5. Wear the correct protectors to protect your eyes and body.
6. Correctly tighten the tip to prevent backfire.
 - When fixing a tip to the torch, tighten the nut with the two wrenches attached.
 - If the tip is tighten excessively, it will be heated during cutting and tightened still more, making it difficult to remove the tip.
 - Avoid damaging the taper of the tip because it may cause backfire.
7. Check any leakage of gas from the connection part of the distributor, hoses and torch with soapsuds.

You must not use oil or grease on the connection of the oxygen pipe to avoid backfire. Because it may lead to explosion.

8. Check the following when igniting:
 - Place the torch on the torch holder before igniting.
 - Always wear the required protectors (gauntlets, helmet, goggles, etc.)
 - Check for any obstacles, dangerous materials and flammables near or in the direction of cutting.
 - Check the gas pressure. (The pressure must be in the right range)
9. When the temperature of torch and tip are high, you must wear gauntlets to carry them. The surface temperature of them is very high after cutting, so you don' t touch them even you wear gauntlets.

2 Location of safety labels

Safety labels and other labels for correct operation are affixed to the machine.

1. Carefully read the labels and follow the instructions on them when operating the machine.
2. Never remove the labels. Keep them clean and legible at all times.

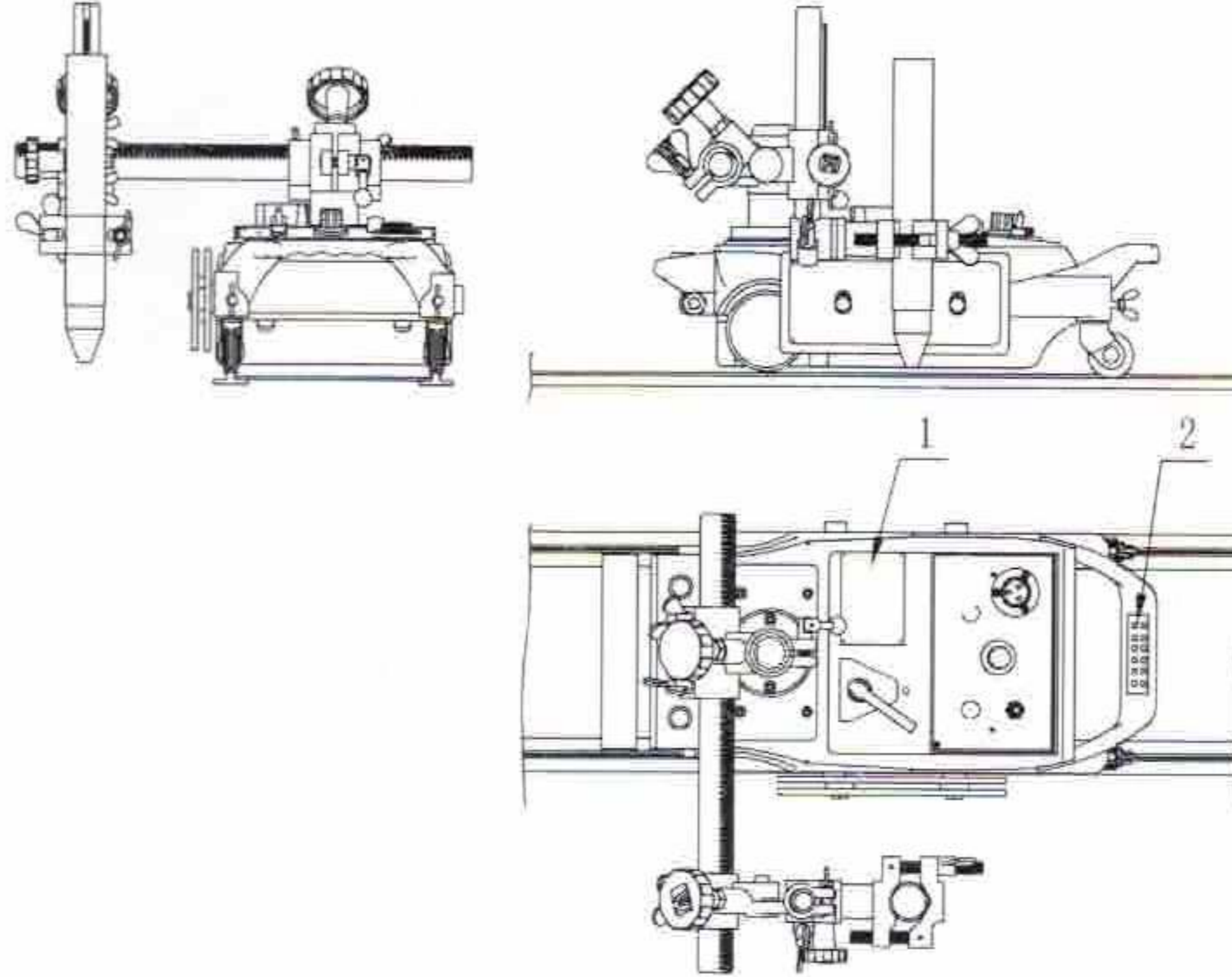

3 Outline of machine

3.1 Characters

"CG1-30K" flame cutter is one of main products of our company. It is designed well and beautiful. We adopt many advices of customers and hold technical seminars. Then, we do technical innovations and optimizations for it. This machine adopts new material, which improves the serviceability, durability and heat-insulating property.

This machine can be matched with plasma torch to cut stainless steel and non-ferrous metals. It is equipped with interface of arcing. It can control the arcing of plasma easily. The machine is suitable for straight cutting. It also can do circle cutting ($> \varnothing 200\text{mm}$). The speed of it is the 3-4 times of general carriage. It meets with the need of plasma sheet cutting. The machine can be used on the fields of shipbuilding, bridge, metallurgy, heavy machinery and so on.

3.2 Name and function of each section

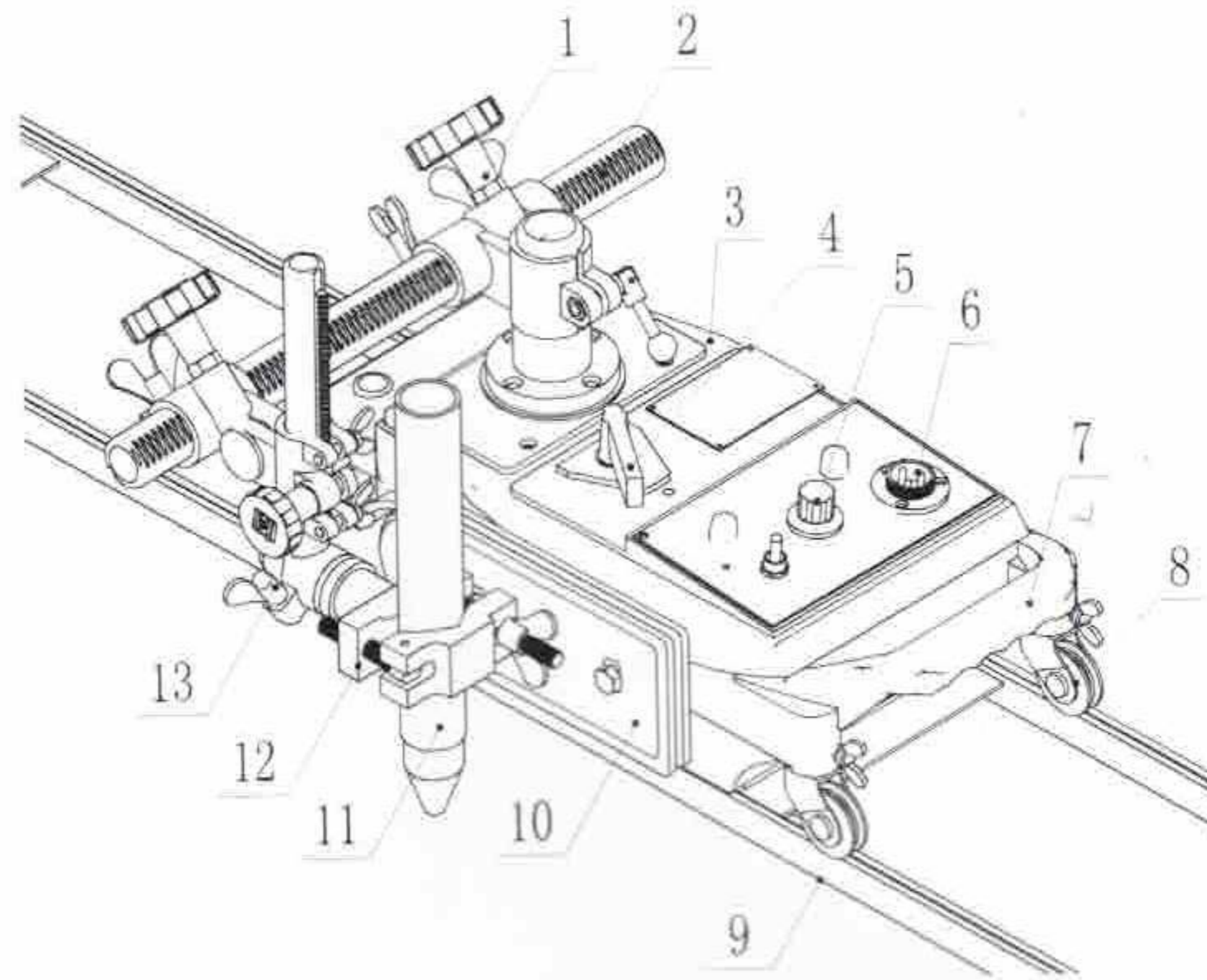

- | | |
|--|---|
| 1.left and right moving seat | 7.portable handle |
| 2.cross moving rack | 8.universal wheel |
| 3.main body | 9.guide |
| 4.clutch lever : Align the end of lever with " STOP" is detach. Align the end of lever with " START" is combination. | 10. insulation board : prevent the heat produced by cutting from going into the inner of machine. |
| 5.Speed control knob: The speed is increased from " 0" to" 10" ; The speed is decreased from " 10" to" 0" | 11.plasma torch |
| 6.power outlet | 12.plasma holder |
| | 13.up and down moving assembly of torch |

3.3 Specifications

1.Weight	: 12.5 kilograms
2. Machine dimension	: 435 mm×210 mm×240 mm
3. Speed control	: silicon control
4. Power source	: AC 220V±10% 50HZ
5. Cutting speed	:50~4500/mm/min
6. Cutting thickness	Option as per cutting required
7.Groove angle	:0-45 degrees
8.Diameteral of cutting circle	:ø200-ø2000mm
10.Motor	:DC 110V 50HZ 30W 4200r/min

4 Preparation for operation

4.1 Contents of package

Carefully take the machine out of its case.

The contents of the standard package are shown below. Check them carefully before assembling the machine.

1. Body	1 set
2. Torch unit assemblage	1set
3. Moving unit assemblage	1set (including left-right, up-down moving unit assemblage and gear rack)
4. Tip (acetylene)	1# 2# 3 #, 2 pc each
5. Power wire	1pc
6. Specification sheets and certificate of qualification	1 pc each
7. Gas-in connector /pressure cat	1set
8. Ball-pane screw M4	2pc
Standard accessory	
1. Cutting circle unit assemblage	1set
2. convex guide rail	2pc (1.8m/pc) or grooved guide rail 1pc (1.8m)

4.2 Machine assembly

1. Take the machine out of case.
2. Make left-right moving seat (2) connect with frame seat of main machine (1).
3. Adjust a suitable range. Then, tighten it with screws.
4. Take up-down unit assemblage (4) out and equip it to cross gear rack (3). Adjust a suitable range. Then, tighten it with butterfly screws.

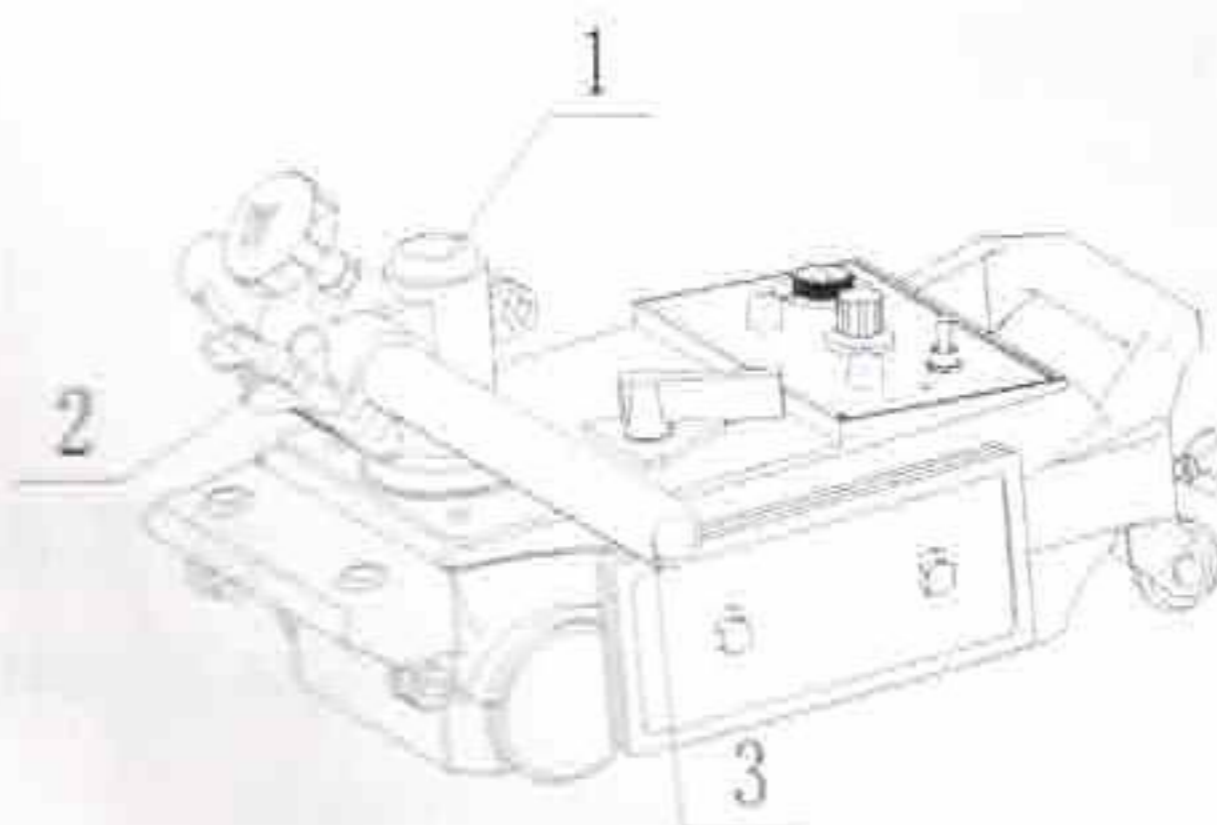

5. Take the torch assembly out and connect the seat (1). Adjust a suitable degree and fix it

with two M4 screws.

6. Release butterfly screws of torch holder and push the torch into hole slowly. Then, tighten butterfly screws.

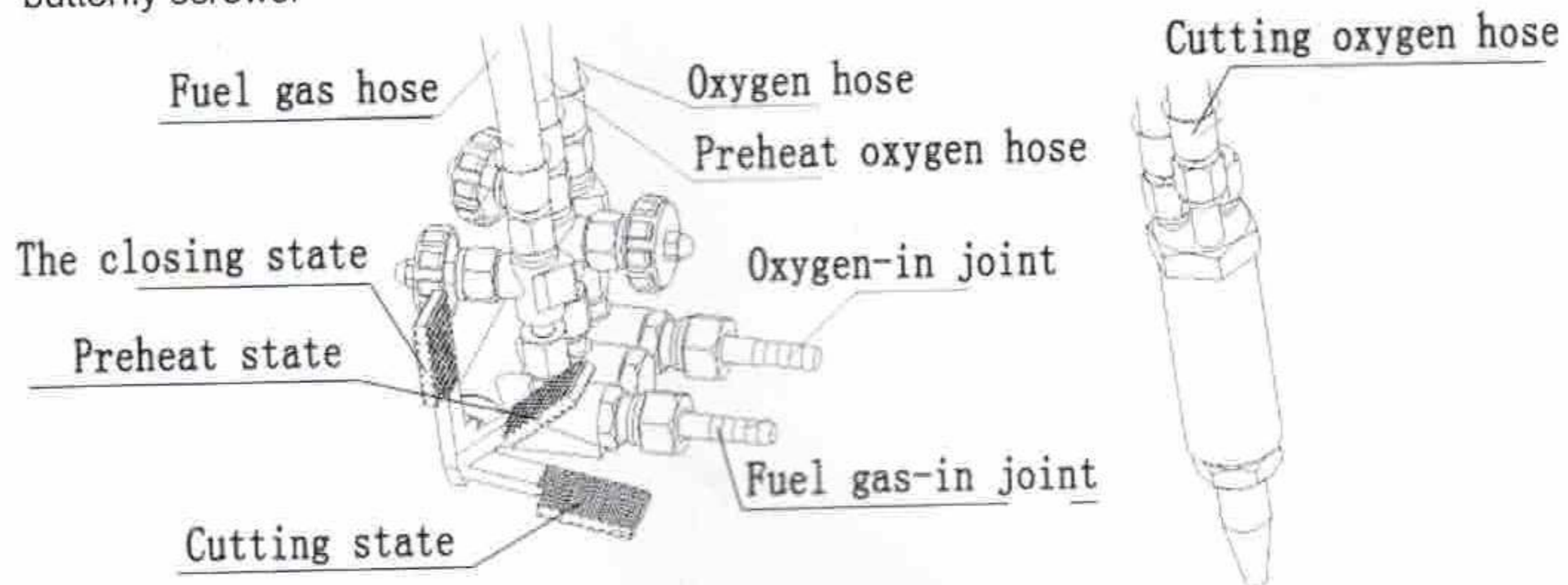

4.3 Preparation for operation



4.3.1 Power cable connection

1. Before plugging the metal plug into the socket on the guidance panel, you must ensure there is no sundry or dust.
2. The metal plugs has threads, therefore, you should fully tighten them so that they will not loose during operation.

4.3.2 Tip connection

1. Select a proper tip according to the thickness of the steel plate and fix it to the torch. (Refer to the cable of Cutting Data to select a tip)
 - When fixing a tip to the torch, tighten the nut with the two wrenches.
 - If the tip is tightened excessively, it will be heated during cutting and tightened still more, making it difficult to remove the tip.
 - In addition, avoid damaging the taper of the tip since this may cause backfire.

4.3.3 Speed setting

When the machine starts to operate, you should turn the clutch on to adjust cutting speed according to thickness of steel. It can increase the cutting speed along " 0" toward " 10" clockwise, and decrease the speed along " 10" toward " 0" anti-clockwise.

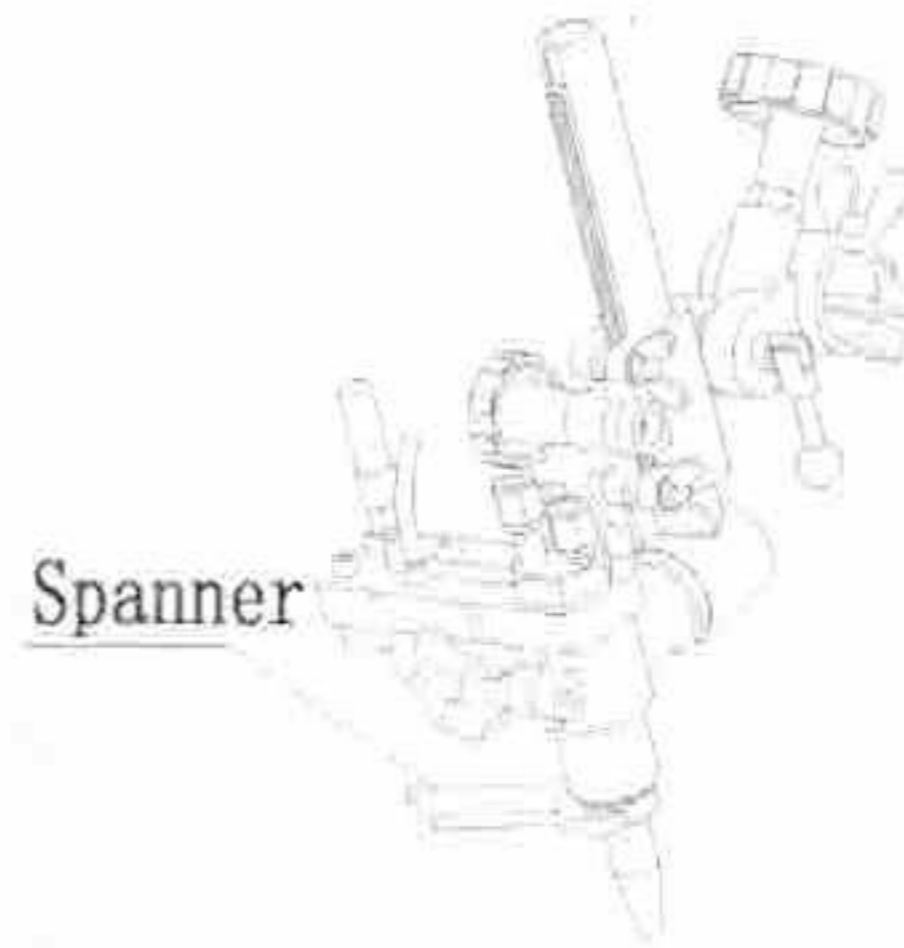
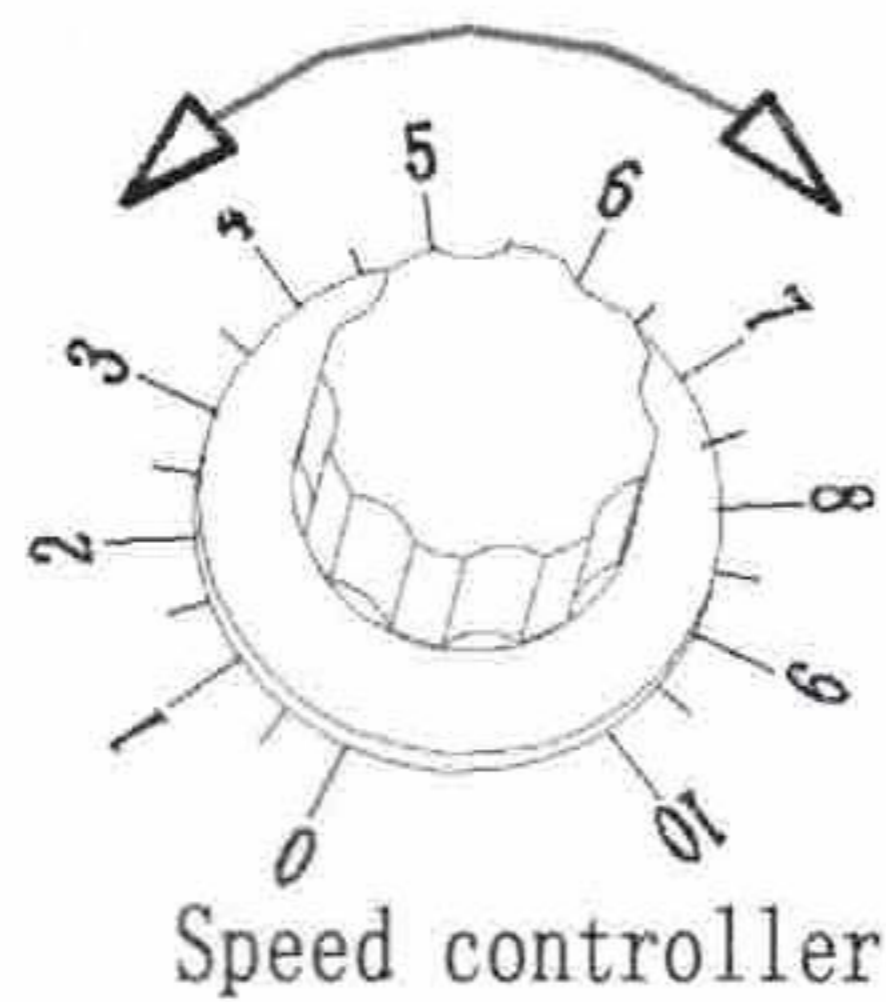

5 Cutting operation

5.1 Safety precaution before operation

5.1.1 Safety precautions for

grounding the machine



The cable of this machine is equipped with a grounding wire.

For safety, be sure to ground the wire as follows, in addition to checking the connection of the power cable. (As shown in diagram)

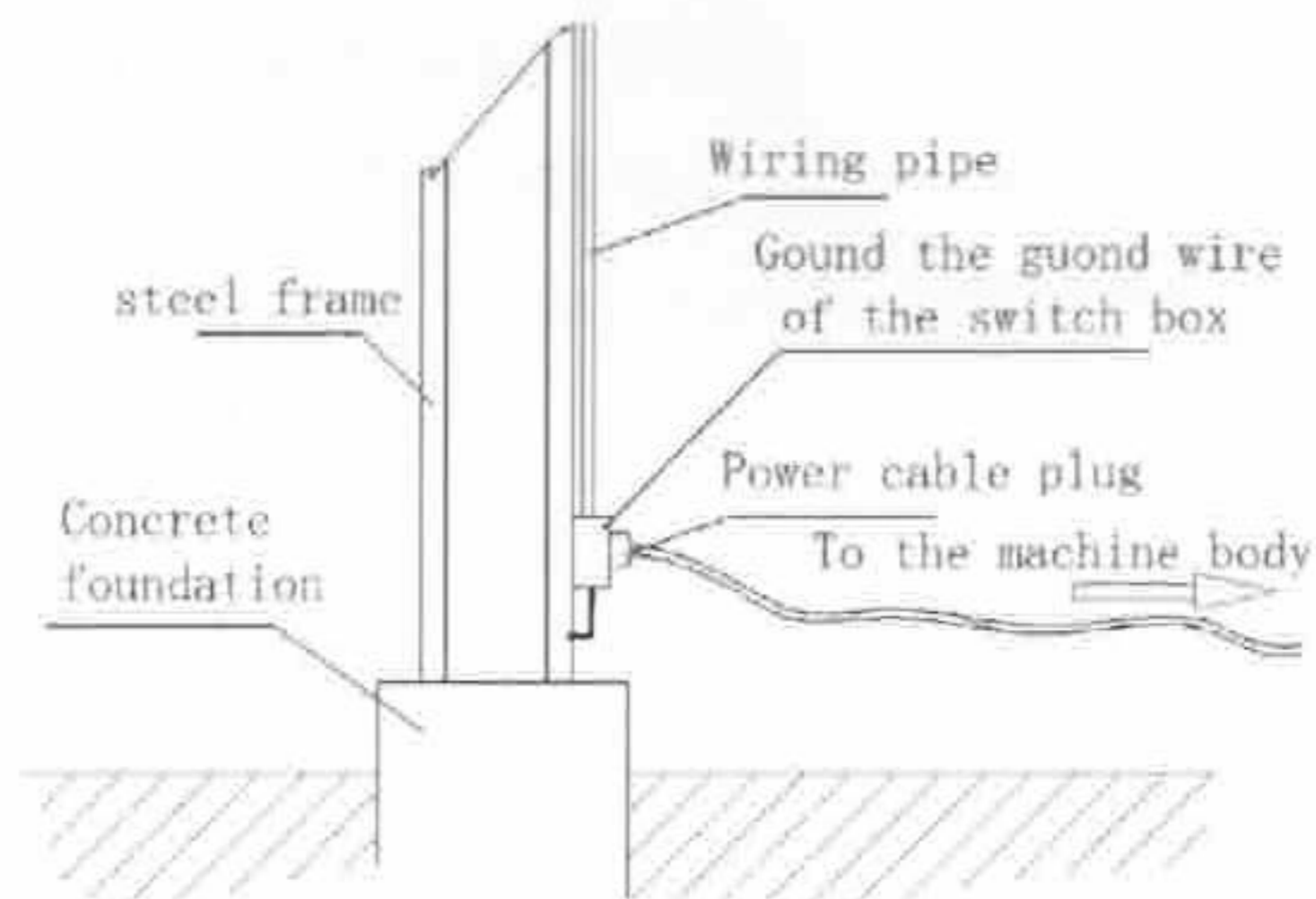

5.1.2 Tip choose

Refer to the *cable of Cutting Data* and select a proper tip according to the thickness of the steel plate. You should choose a bigger grade tip if the steel is rust-eaten seriously or the cutting angle of groove is bigger than 20°.

5.1.3 Operation of the changeover switch

1. The changeover switch is used to change forward or backward direction. Before cutting, you should check the cutting direction.
2. If you want to change the cutting direction, you should make the driving button be on the " stop " position, then change the cutting direction after the machine stops.

NOTE: Before you turn on power, it is necessary to check if the driving button is on the " stop " position. It is very dangerous if the driving button is on the position of " on "

5.2 Ignition and flame adjustment

NOTE: Adjust the gas pressure according to the *Cutting Data*. The data shows the pressure of all valves which are open. Readjust the pressure after ignition.

1. First, put the fast distributor knob on the position of preheating.

2. Open the fuel gas valves 1/4 a turn, the preheating oxygen valves 1/2 a turn, and light the torch with an igniter.
3. Then, open the preheating oxygen valve gradually until a white cone of the standard flame gas been obtained. (The incandescent area should be uniform and about 5-6 mm in length.)
4. Open the cutting oxygen value fully. Readjust the flame if its state has changed. A disorderly flow of cutting oxygen will adversely affect the quality of the cutting surface. In such a case, close the preheating oxygen valve and fuel gas valve. You should clean the tip with a suitable needle while the cutting oxygen is flowing.
5. Appropriate distance between the end of tip and cutting surface:
 - Acetylene gas8-10mm
 - LPG gas5-8mm
6. Neutral flame ensures a good quality of cutting surfaces. (Oxygen flame may be used for groove cutting.)

Oxygen flame causes short cutting-oxygen current, allowing slugs to adhere, melting the upper edge of the cutting surface, and causing adverse effects on the cutting surface. Similar defects will occur when the pressure of cutting oxygen is too high.

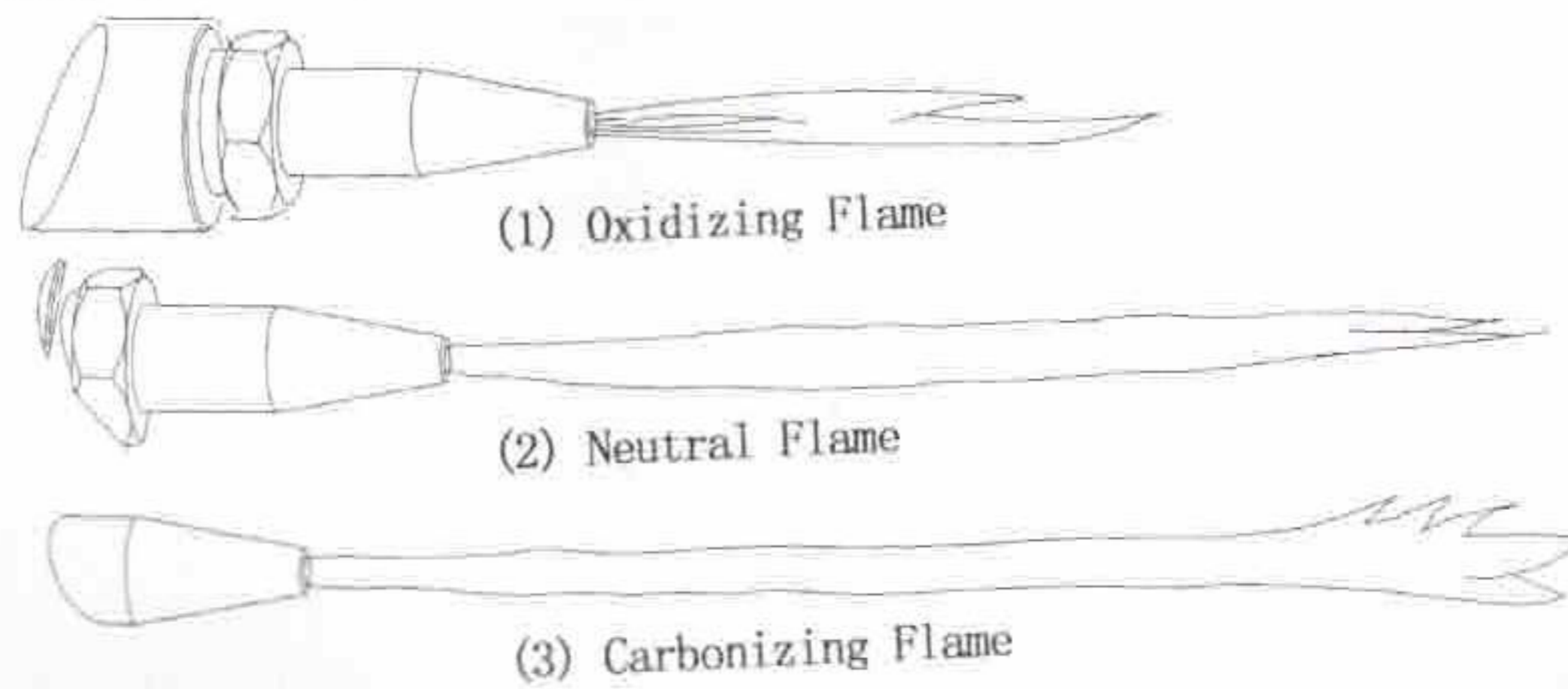

5.3 Methods of cutting and piercing

1. Cut from the end of steel plate.
 2. Pierce steel plate before cutting.
 3. Drill a hole before cutting.
- Piercing method
- 1) Ignite and adjust the flame.
 - 2) Thoroughly preheat the cutting point until it is on state of white hot.
 - 3) Open the cutting oxygen valve to make the flame pierce the steel plate. The tip should be about 15-20 mm from the plate to prevent slag from splashing onto the tip and adhering there, which will shorten the working life of the tip.

5.4 Cutting operation and steps of blanking flame

1. Align the tip with cutting start point and ignite, then adjust the flame.
2. Preheat the cutting start point fully.
3. Open the oxygen gas valves above 1/8 a turn.
4. Check the cutting state and use speed controller to control cutting speed. You can refer cutting data to check cutting speed.
5. Blank the flame in the following steps after cutting.

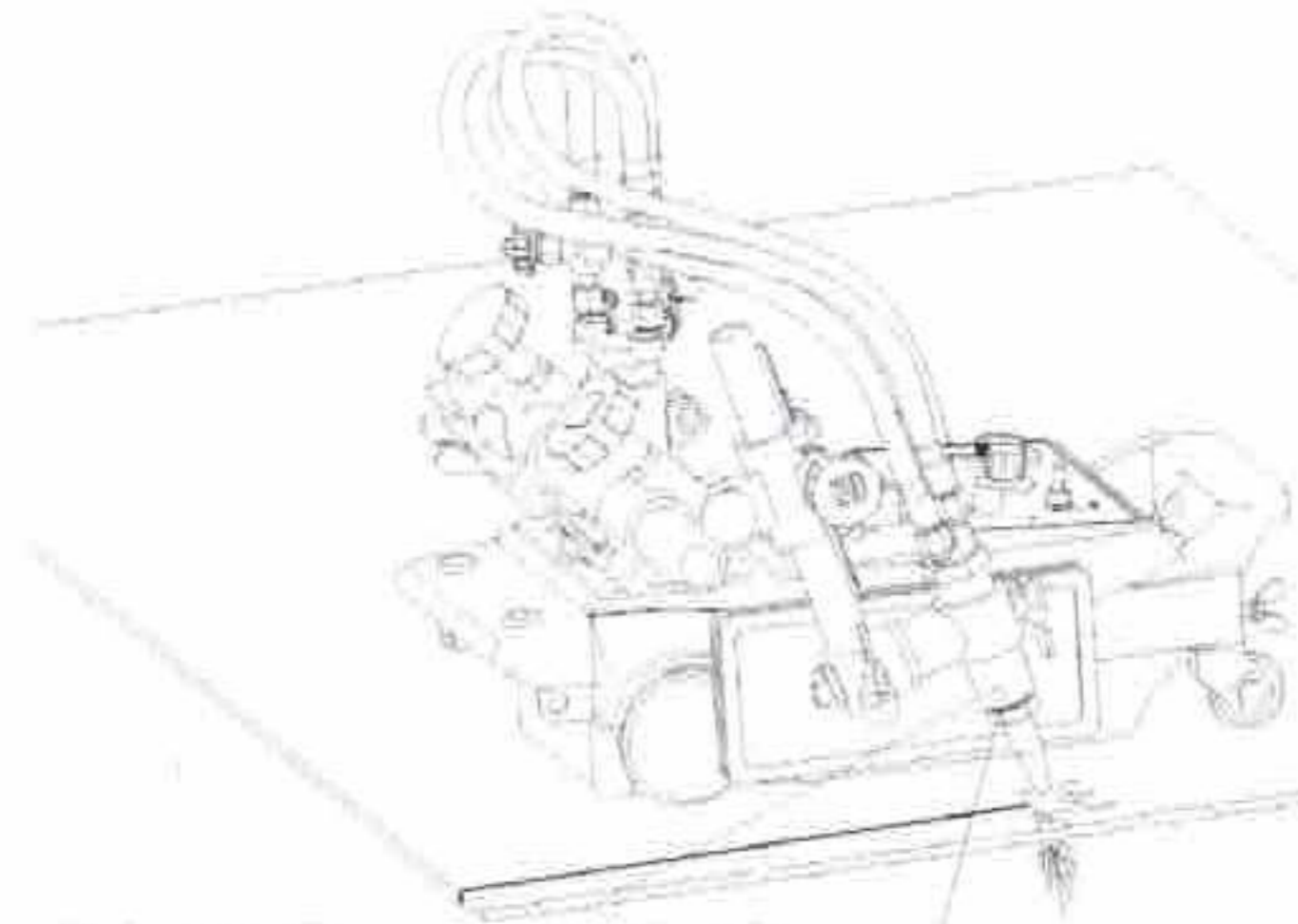

Release the screws and make the torch lean toward a little.

- 1) Make the fast distributor knob be on the " off" position, which can cut off all gas. You need not to close two-way valve.
- 2) When you cut on next time, you only need to operate fast distributor knob. The size of preheating flame doesn't be varied. So, it can improve the efficiency.

5.4.1 Sheet cut

When you cut sheet (thickness $\leq 6\text{mm}$), you should do the following steps.

1. Choose suitable tip and pressure according to cutting data. Then adjust the weak flame.
2. Release the screw on the up-down unit assemblage's inner flank to make the tip lean toward a little. Then, do cutting. In the process of cutting, if the pressure of cutting oxygen is too high or the cutting oxygen is preheated too high, it will lead to a bad declutch or having dross on the cutting bottom.

5.4.2 Groove cut

When cutting groove, use the angle (use 5° as its basic unit) on the torch holder and allocate the torch on an expected angle. When choosing a tip for groove cutting, the thickness of the steel plate is " L " as shown in following picture. In order to compensate the over-dose heat loss due to the groove cutting, the operator should choose an upper rank tip based on the Cutting Data. Slight oxygenized flame will lead to an increase of efficiency and set the speed with a decrease of 20%-30%. The groove cutting surface in the diagram is a result of inadequate preheating, which requires to choose tip again and readjust preheating and speed.

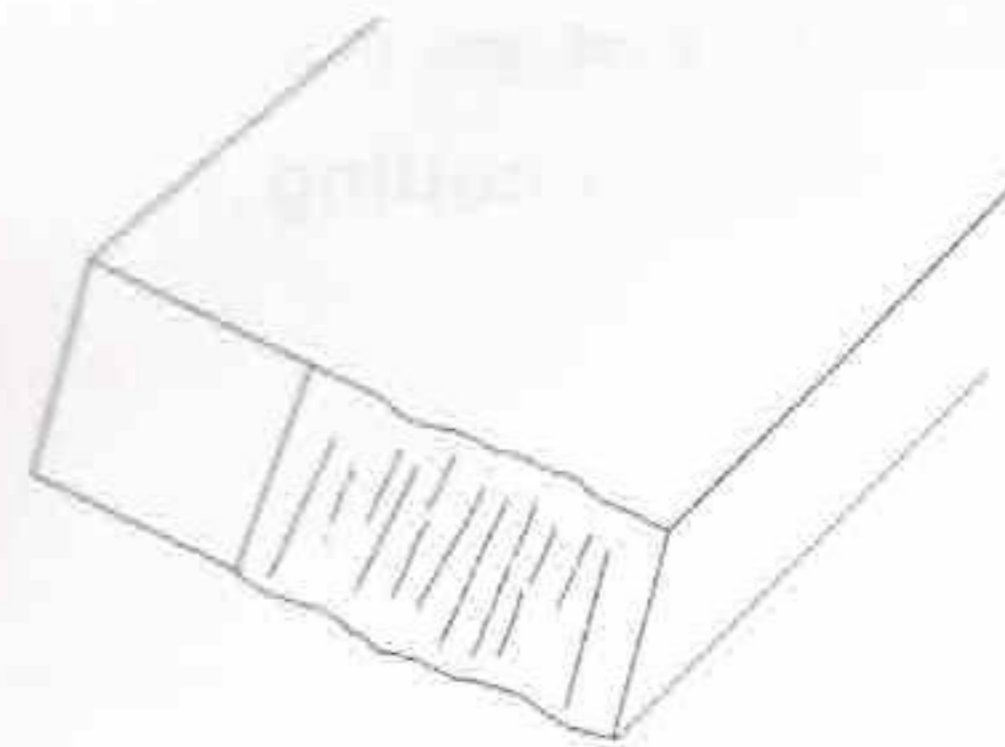
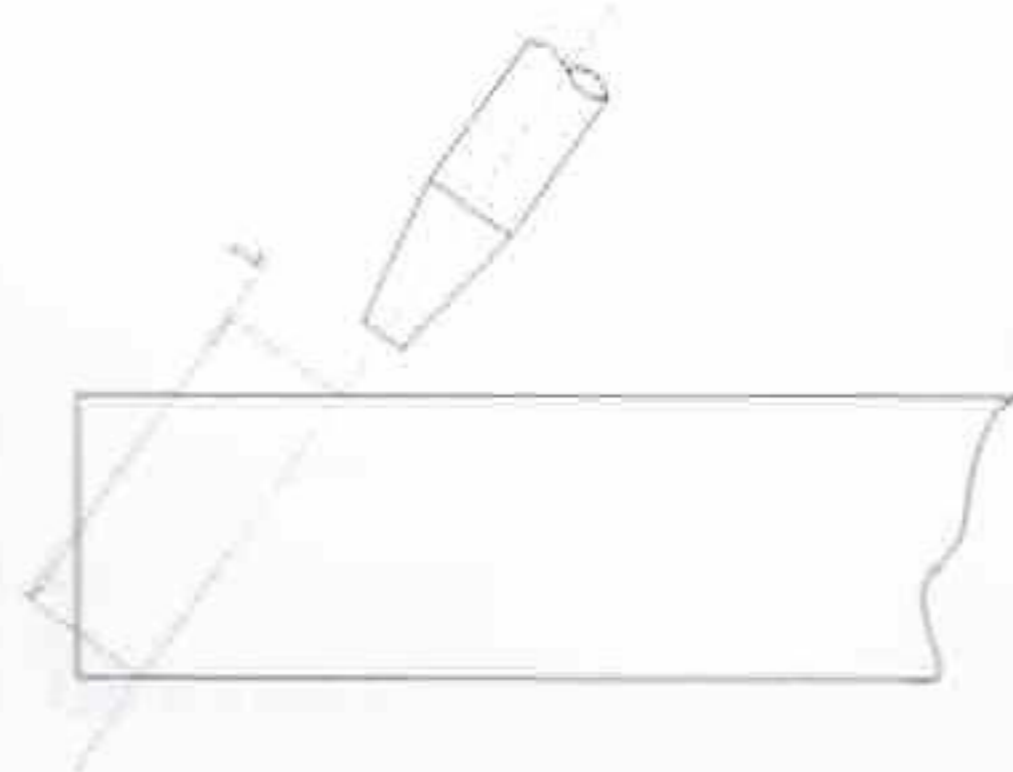

5.4.3 Linear cut

When you use the stand-by rail, you should make the rail parallel with the line of cut and the distance is about 80-100mm. Adjust the two driving wheels to make them be on inside groove of rail. Make universal wheel be on inside groove of rail and tighten locating butterfly screw. Put the tip on cutting start point and ignite, then adjust the flame. Preheat the cutting start point fully and turn the cutting oxygen valve and power on. Adjust cutting speed by speed controller according to the state of cutting

You should open the cutting oxygen valve fully. When the gas pressure of cutting sheet is too high, you can use this valve to decrease pressure to make the cutting be easy.

If you use prolonged rail, the cutting length can be increase. If there is big soil block or splashing on rail, the machine will shock strongly on this point and lead to damages of cutting surface. So, you must ensure there is no barrier. If there is barrier, you should clean it. Don't make hoses hanged on the brim of steel plate.

5.4.4 Arc cut (emergency work)

The method of cutting big circle is different with the method of cutting small circle. The following picture shows the corresponding equipments in the process of cutting. You also can cut concentric circle with two torches at the same time.

1. Make the radius bar (1) put in the holes, which are on the two sides of shell leading end. Tighten the radius bar with M10 nut.
2. Make the radius gauge (2) fixed to radius bar (1) and adjust to a suitable position. Then, tighten it with locating butterfly screw and locate it in the middle of punch signal. Adjust the locating screw to make the driving wheel hanged above steel plate 1-2MM (3/64-5/64). Then, tighten the nut.
3. Release the locating butterfly screws on the two sides of universal wheel to make the universal wheel revolve freely.
4. Install the torch vertically and make the tip on the cutting line. Release the clutch and push the device to walk a cycle along the central locating screw. Then, check whether the machine can walk along the cutting trace.
5. In the process of cutting arc, Must make the hoses and wires not to enwind to bring troubles, which may lead to a poor quality.

Illustration: First, you must drill a 60 degree locating hole on the center of cutting circle.

Small circle cutting

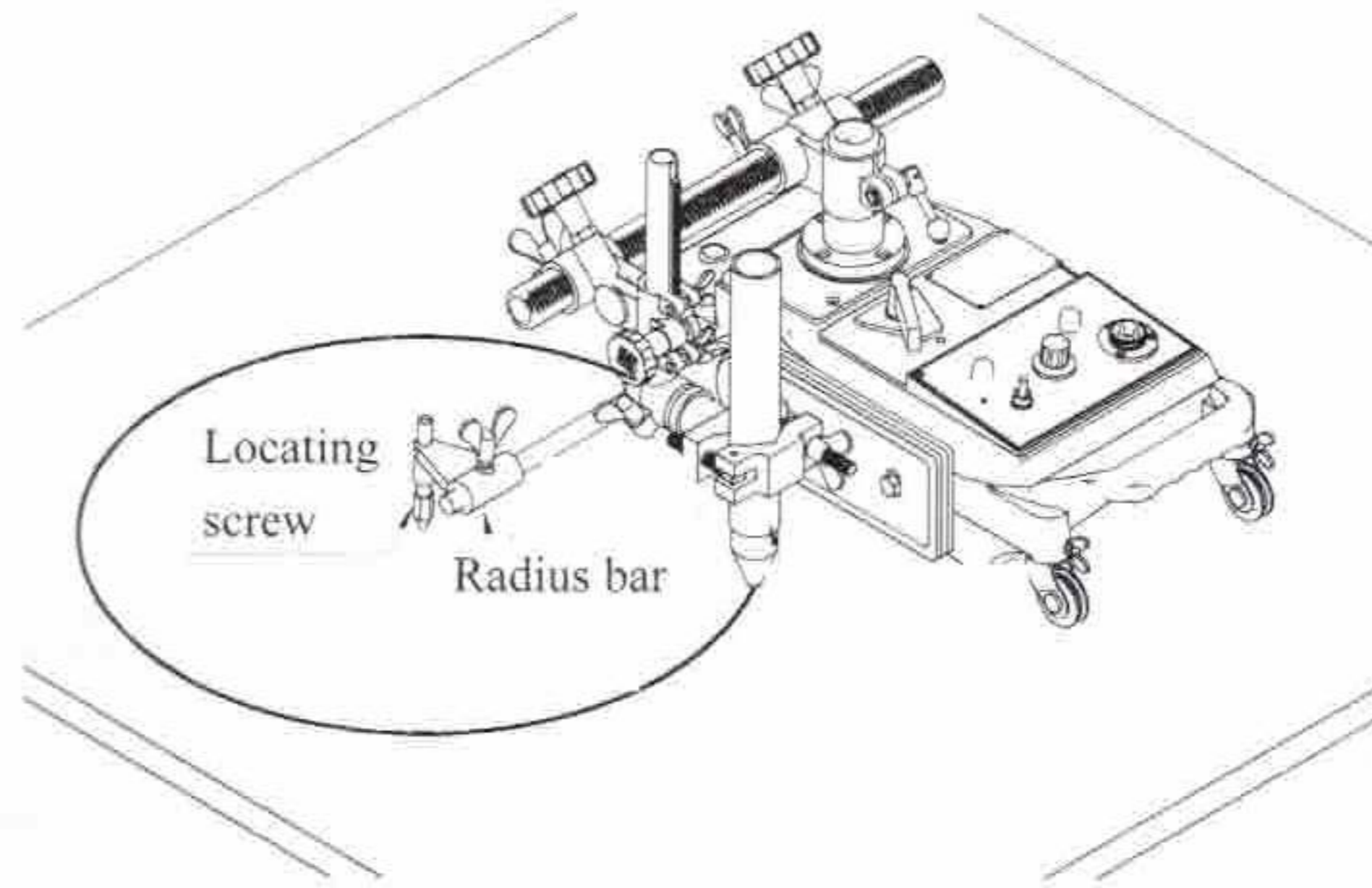

Big circle cutting

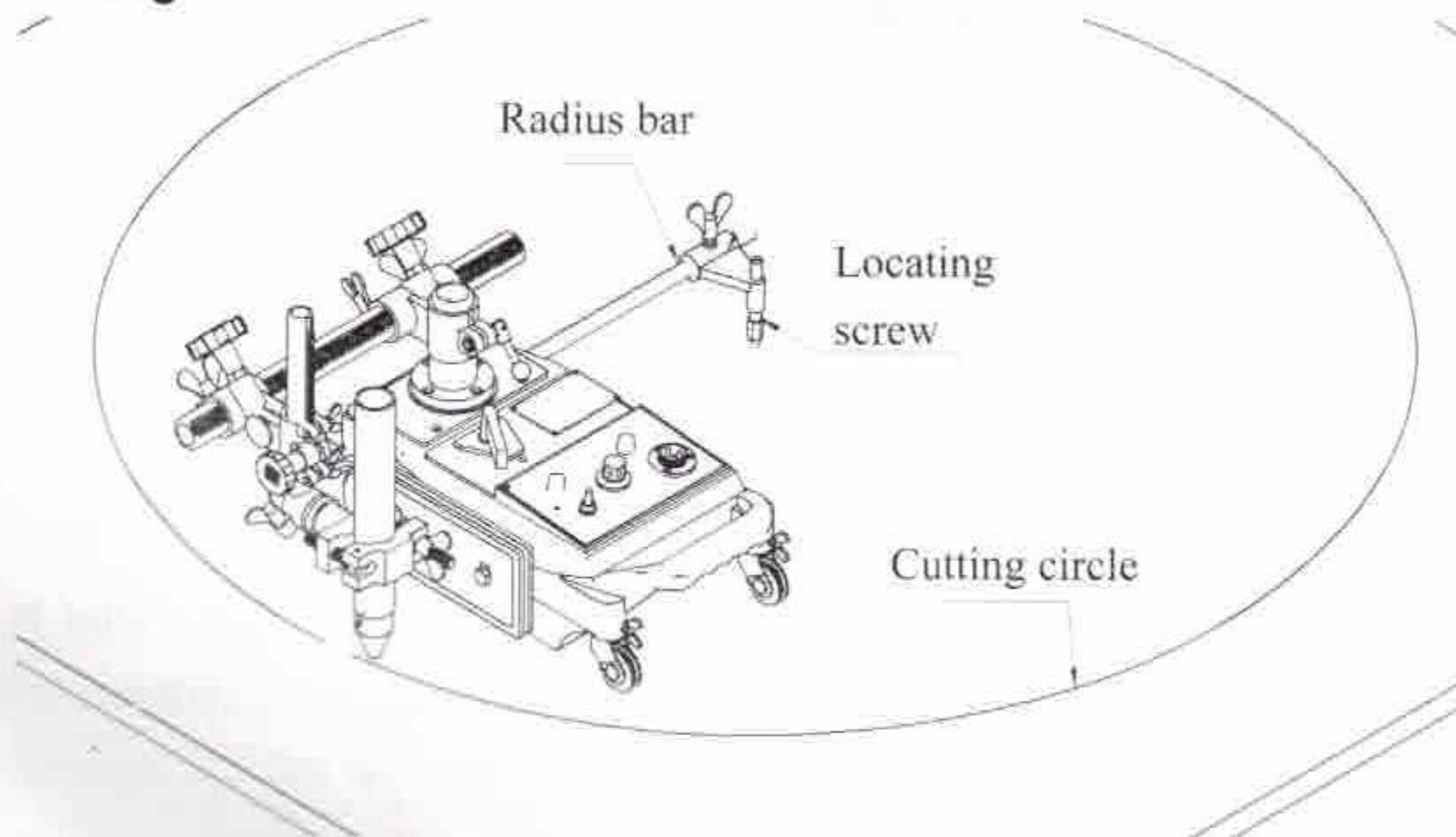

5.5 Safety measures against backfire and flashback

5.5.1 Prevention of backfire

Backfires may cause serious accidents or fire. Be careful to prevent such disaster. When a backfire occurs, you should find the cause. Inspect and maintain the machine correctly before using the machine again.

The followings are causes of backfire:

1. Improper gas pressure adjustment.
2. Overheated tip
3. Dross clogging in tip
4. Damages to the tapered section of tip or torch will cause backfire.

5.5.2 Prevention of flashback

Flashback could cause fire and damage the machine. If there be a hissing sound in the torch, you should quickly take the following action:

1. Close the preheating oxygen valve.
2. Close the fuel gas valve.
3. Close the cutting oxygen valve.

If flashback occurs, you should find the cause and take appropriate action before using the machine again.

6 Maintenance and inspection

Refer to the following points for maintaining and inspecting the machine in order to use the machine under the best conditions.

6.1 Gear case maintenance

Because there are gears and worms that run at a high speed in the gear case, so the operator should remove the shell of the machine, take out the gear case and wash the gears and the case with detergent every six months. When reassembling, we should put new lubricant into the machine.

If the turbine is abraded, we must change a new one.

6.2 Tip maintenance

The durability and security of the tip used in "CG1-30K" gas cutter is very good. The operator should abide the right maintenance and operation precautions in order to ensure cutting quality.

1. Put the torch up a little and keep a 15mm distance from the plate when piercing, in order to avoid damaging the tip by backfire.
2. Clean the jet hole of the tip carefully using suitable dip washer.
3. Pay attention not to damage taper seat.

Replace the tip if the following cases occur.

- a. The injection stream of cutting oxygen can't extend straightly after clean.
- b. The injection stream of cutting oxygen bifurcates at the end.
- c. The click may be heard from the tip when cutting.
- d. The gas leaks and burns at the hold-down nut.
- e. The preheat flame is out-of-flatness.

6.3 Carbon brush maintenance

Remove the carbon brush cap to ensure the state of carbon brush every three months or 1000 hours. If the length of the carbon brush doesn't reach 3mm, the operator should change it to a new one. When change the carbon brush, the operator must check that whether put the carbon brush in right place. The carbon brush must be put in a right way and the flexure should be consistent with the commutator.

7 Troubleshooting

1) The motor does not run.

Possible Cause	Correction
1) The power is off. Disconnection of 10Ω resistance	Turn on the power and check whether the resistance is good.
2) Carbon brush of motor is jammed	Take out the carbon brush, grind the forepart and fix it to make it connected well.
3) The clutch is not " on" .	Make the clutch be " on" .
4) The connecting system of Gear case doesn't work well.	Check whether the pins of gear case drop.

2) During operation, the machine vibrates much and brings a big noise.

Possible Cause	Correction
1) There are obstacles on the rail.	Clean the obstacles out.
2) Gear damage.	Check whether the turbine has been worn and whether worm has bad burrs. Then replace the bad parts.
3) Motor damage	Change the motor.

3) Gas leakage and fire leakage

Possible Cause	Correction
1)The 30° taper is not contacted well due to incorrect usage.	Mend the 30° taper carefully with thin emery cloth to make it contacted well.
2) The cater nut is not tightened.	Tighten the cater nut.

4) The cutting flame is instable

Possible Cause	Correction
1) The duct of tip is jammed by impurity.	Make the duct expedite with needle.
2) The gas pressure is not enough and oxygen fineness is low.	Check whether air-feed pressure and oxygen fineness are in the specified range.

8

Wiring diagram

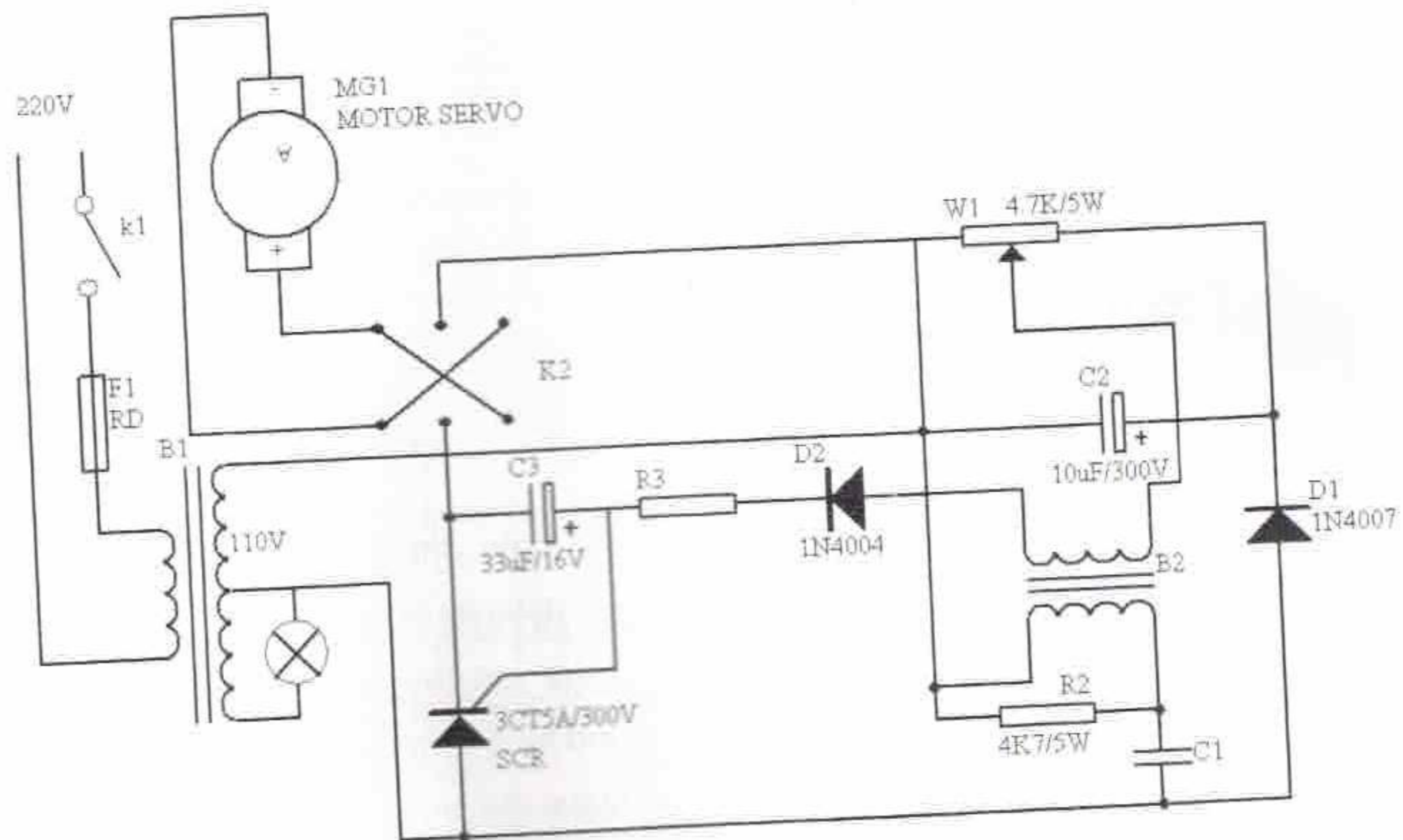

9

Maintenance illustration:

1. We guarantee to keep the machine in good repair in half year based on invoice from the day we sell it
2. If the failures are generated because of the bad making after checked by the quality inspector, the manufactory will see after.
3. If the failures are generated because of carriage, improper keeping, operating not according to the instruction manual and beyond the specified range of voltage, we can' t guarantee to keep the machine in good repair.
4. If the failures are generated because of the taking apart by unprofessional person, we can' t guarantee to keep the machine in good repair.

(Illustration: Do not inform if the specifications and technical contents of the machine have been modified!)

Acknowledgment

Honored company to choose the company' s production

The main production of the company:

CG1-30	Carriage gas flame cutter
CG1-30A	Precision gas flame cutter
CG1-30H	Fast carriage gas cutter (Can ticket plasma torch cutter)
CG1-100	Gas flame cutter (two torches)
CG1-100	Aprecision gas flame cutter (two torches)
CGD2-100	Multi-head gas flame cutter (three-five groups of torches)
CG1-2H	H beam cutter
CG1-75	Ingot gas cutting machine
CG1-13	Multi-direction gas cutter
CG2-150	Profiling gas cutter
CG2-150A	Profiling gas cutter (cutting dia.1800mm)
CG2-2700	Move style profiling gas cutter (cutting dia.2700mm)
CG2-600	Circular cutter
CG2-11	Magnet pipe gas cutter
CG2-11G	Hand pipe cutter
CG2-11D	Automatic pipe gas cutter
HK-30	Portable cutting machine
HK-30A	Multi-using cutter
HK-55	Handy auto kit
HK-66	Metal cutter
HW-2000	Automatic welding machine
HK SERIES	Auto- welding carriage
KMQ SERIES	Portable profiling cutter
LGK8 SERIES	Air plasms cutting machines
CG SERIES	Multi-head straight cutting machines (five-twenty groups of torches)
HNC SERIES	Numerical control flame / plasma cutting machine
ZYHC SERIES	Auto-control far-infrared electricity welding dryer machines
TRB SERIES	Welding dryer
YJJ-A SERIES	Suction flux drying machine

WELDING&CUTTING FUTTINGS:

The regulator of Oxygen, acetylene , propane , argon and CO2; Handmade-welding torch and handmade-welding tip;

Acetylene, propane equi-pressure tip, pitch needle, conduit conflux and so on cutting and welding fittings.